

MANIACCESS

120 AETJ 120 AETJ 3D

Concentrated technology



 **MANITOU**

IDEAL FOR ALL KINDS OF WORK



Standard Equipment

- Negative brakes
- Lifting brackets
- Hour meter
- Warning buzzer in the basket
- 220 V predisposal
- Voltage indicator
- Basket with mesh floor for better visibility
- Safety lowering systems
- No marking tyres
- Buscan technology
- Diagnostic help integrated in lowered control box
- Electric motors

Optional Equipments

- Flashing light
- All motion alarm
- Flashing beacon
- Gel type battery
- **Extreme cold condition option**



The 120 AETJ :

A narrow machine with outstanding outreach

Because making the best use of space is becoming more and more important, Manitou has produced the 120 AETJ.

The 120AETJ is a compact electric articulating boom (working height 12m), specially designed for all your maintenance and logistical operations.



Very compact

With an overall width of only 1.2 metres and a stowed height of less than 2.0 metres enables the **120 AETJ** to access any building fitted with standard doorways.

Inside and outside use

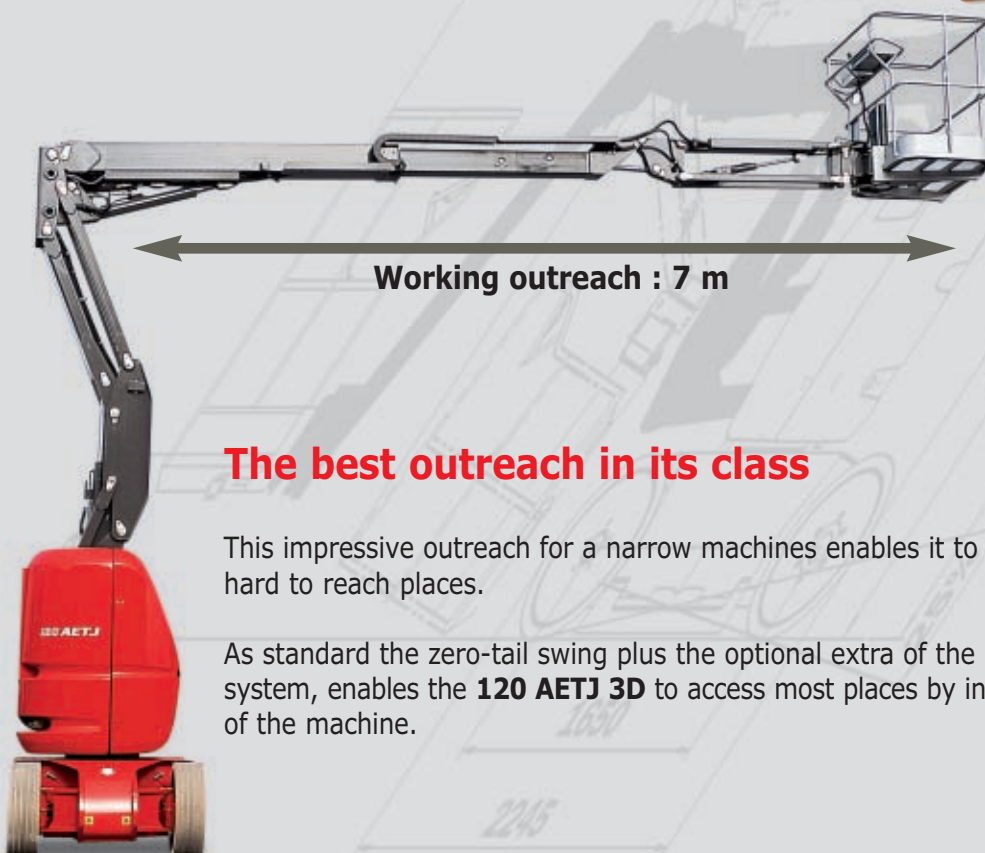

The best outreach in its class

This impressive outreach for a narrow machines enables it to overcome most obstacles and hard to reach places.

As standard the zero-tail swing plus the optional extra of the 3 dimensional suspended arm system, enables the **120 AETJ 3D** to access most places by increasing the working envelope of the machine.

ENTER THE THIR



Safety

- Hydraulic anti-roll system: activated as soon as the arm is lifted to guarantee maximum safety for the operator.
- 10 cm ground clearance in "transport" mode.



Comfort

- Spacious basket: allows 2 operators to work in good conditions.
- Twin handrails to protect hands.
- Tool-tidy allows equipment to be put down safely.



Fittings

- Non-marking tyres as standard, ideal for interior working without leaving marks on your flooring.

Wide tyres : leaves fewer impressions on the flooring.

Easy to use

Control box ergonomically designed and simple to use.

- **Safety** : the selected operation is cancelled after 8 seconds if the order is not confirmed.
- Electro-proportional movement for smoother and more precise operation.
- Movement selected by push buttons.



D DIMENSION...



Convenient

Transport / storage position.

JIB 3 D

- 140° tilt
- 140° Rotation





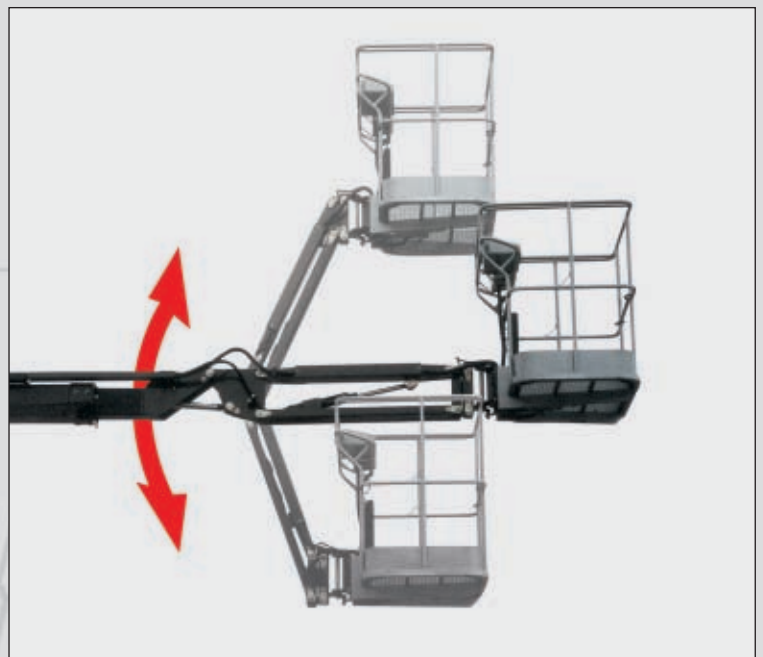



High performance

The 3 dimensional suspended arm enables the **Manitou** access platform to be used on even the most restricted industrial sites.











120 AETJ 3 D model

120 AETJ

	Safe Working Load200 kg Outside use(SWL 200 kg)
	Working height11.95 m Platform height9.95 m
	Overall length5.48 m Lenght (transport position)3.74 m Overall width1.20 m Overall height1.99 m Basket size1.20 x 0.96 m Max. outreach7 m/4.77 m Ground clearance10 cm Turning radius (inside/outside)1.55 m/3.34 m
	Travel speed0 to 6 Km/h
	Basket rotation140° Turret rotation350° Jib tilting140°
	Traction battery48 V/300 Ah (C5) Integrated charger48 V/60 A
	Gradeability25% Max. slope accepted5% or 3° Hydraulic tank12 l.
	Tyresno marking - 600 X 190 2 wheel drive (rear) et 2 steering wheel (front)
	Weight6550 kg

120 AETJ 3D

	Safe Working Load200 kg Outside use(SWL 200 kg)
	Working height11.95 m Platform height9.95 m
	Overall length5.48 m Lenght (transport position)3.74 m Overall width1.20 m Overall height1.99 m Basket size1.20 x 0.96 m Max. outreach7 m/4.77 m Ground clearance10 cm Turning radius (inside/outside)1.55 m/3.34 m
	Travel speed0 to 6 Km/h
	Basket rotation140° Turret rotation350° Jib tilting140° Rotation du jib140°
	Traction battery48 V/300 Ah (C5) Integrated charger48 V/60 A
	Gradeability25% Max. slope accepted5% or 3° Hydraulic tank12 l.
	Tyresno marking - 600 X 190 2 wheel drive (rear) et 2 steering wheel (front)
	Weight6550 kg

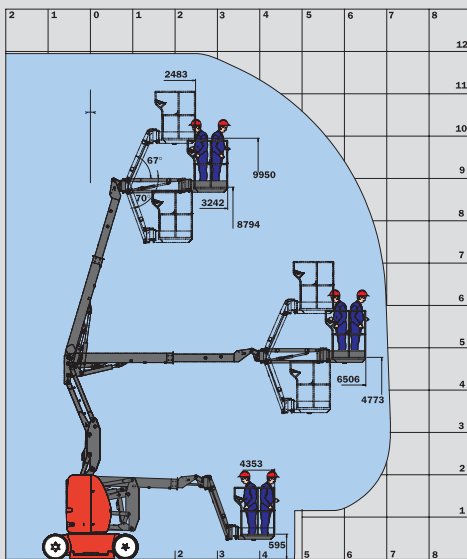

120 AETJ
120 AETJ 3D

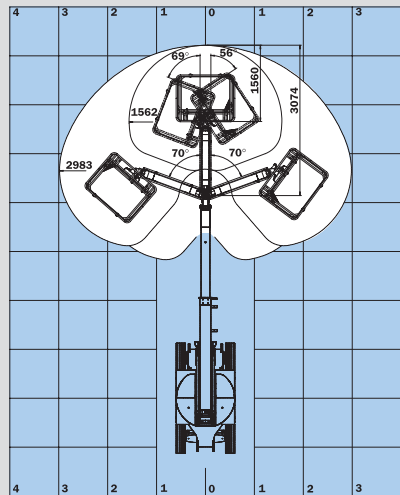

120 AETJ 3D

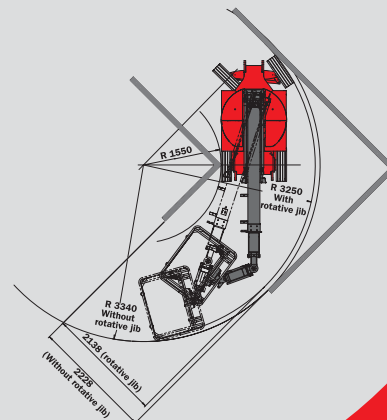
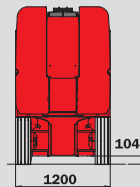
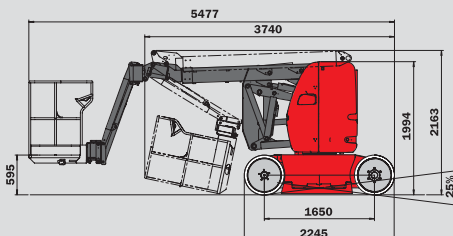

This publication in no way constitutes an offer and the company reserves the right to alter specification without prior notice. The MANITOU models presented in this brochure can be supplied complete with optional equipment attachments.

